

DEVELOPMENT OF STANDARD WATER MILLS IN UTTARANCHAL

R.P. Saini and **Arun Kumar**
SSO *Head*
Alternate Hydro Energy Centre
Indian Institute of Technology, Roorkee
Roorkee

ABSTRACT

The traditional water mills have low output with primarily use of grinding. The upgradation and improvement of these water mills is an effective and sustainable way of meeting the energy needs of a major section of the hilly people. This paper discuss the standard water mills developed in order to cover the entire range of water mills sites in Uttaranchal. Based on the site data available, 3 standard water mills have been designed, developed and tested for their performance. The developed water mills have been found efficient. The installation, operation and maintenance of the developed system have also been discussed.

INTRODUCTION

The idea of using energy in water and converting it into mechanical energy was known to the mankind since long. In ancient times, the mechanical power was developed by passing flowing water through wheels, such wheels known as water wheels were used in China, India, Egypt and later in Europe. Traditional water mills for grinding are being widely used in the Himalayan regions and about 2.5 lacs traditional wooden water mills are still in use in Himalayan and Sub-Himalayan regions [1]. Vertical shaft wooden water mills generally used for grinding grains only and are called as “*Gharats*”. These *gharats* operate under a head of 2 to 5 m to produce on an average of 1.0 kW mechanical outputs. In the hills of Uttaranchal water mills have momentous role in utilization of mechanical power from water streams mainly for agro-processing. The traditional water mills have extremely low output, and do not provide enough economic surplus to the mill owners. The output of a traditional water mills less than 1 kW with a very poor efficiency inspire the technologist to improve the existing design of water mills. Therefore improving the efficiency of the traditional water mills and integrated them with other activities can uplift the socio-economic level of the peoples in Uttaranchal.

Based on the survey conducted for water mill sites it has been found that the hydro potential available at these sites upto 5 kW may be considered to be appropriate resources for meeting the energy needs for people. The problem associated with these micro hydropower potential in this range is primarily of economic. Commercially available turbines used as water mills are not available. It becomes costly to fabricate individual turbines tailored to each site. Due to lack of standardization of equipment, these sites may not be economically viable. It is therefore, there is a need to develop cost effective designs of standard water mills.

Further, it is also found that existing water mills are vertical shaft type and being used for grinding grains only. As runner is the most critical component, which can be fitted with the

existing system. A simple, cost effective design of the runner which could be fitted with the other components of traditional water mill, is desired to be developed for upgradation of water mills. Similarly for multipurpose power generating unit the standard size of the equipment considering the different site conditions is desired so that standard size can be produced in mass to bring down the fabrication cost of the equipment and could cover entire range of site parameters (head and discharge). Keeping this in view standard sizes of water mills have been designed and developed.

STATUS OF WATER MILLS IN UTTARANCHAL

There are around 30,000 to 40,000 water mills in the state of Uttaranchal. Out of these water mill sites the data of about 8,000 water mills are made available for their upgradation and development of multipurpose power units. A survey was conducted for water mill sites in Uttaranchal in order to categorize the sites as per the range of head available. Table 1 gives the district wise number of sites surveyed.

Table 1 : District -Wise Number of Water Mill Sites Identified and Surveyed in Uttaranchal [2].

S.No.	District	No.of Sites
1	Chamoli	2589
2	Pauri	1031
3	Uttarkashi	302
4	Tehri Garhwal	1035
5	Rudraprayag	671
6	Almora	73
7	Nainital	238
8	Pithora Garh	2191
9	Dehradun	120
10	Udamsingh Nagar	2
11	Champawat	51
12	Bageshwar	40
	Total	8343

Based on the survey conducted, the status of existing water mill sites found are summarized as follows ;

- (i) Almost all the gharats are of vertical shaft type.
- (ii) Power output at individual gharat is found to be on average below 1.0 kW. This is particularly low because of very poor efficiency of existing system.
- (iii) About 60% of them are working regularly and 40% are seasonal or defunct.
- (iv) All are being used for grinding grains and manufactured locally.

The collected data were analysed and headwise distribution of these sites has been shown in Fig.1.

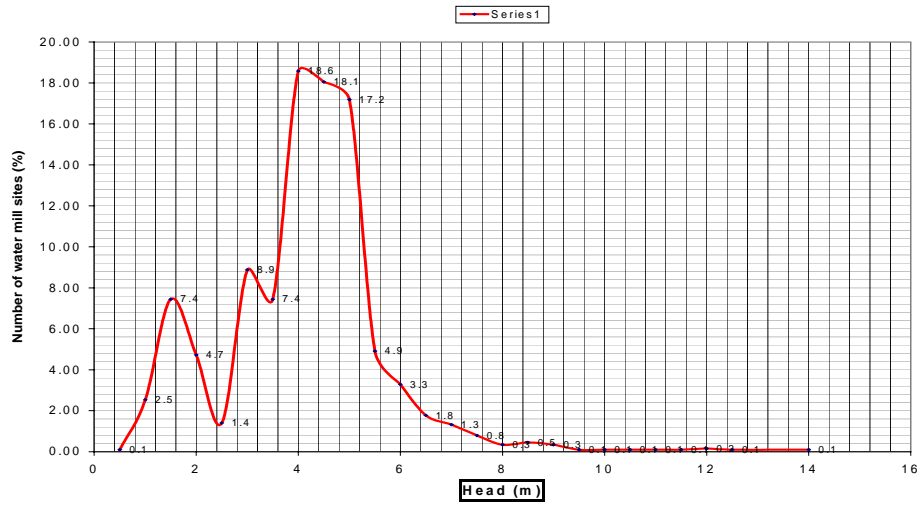

Fig. 1 : Head wise Number of Sites

It can be seen from the Fig.1 that 31% are having operating head less than or equal to 3 m, 67% less than or equal to 7 m but greater than 3 m of operating head and 2% are having greater than 7 m of operating head. The maximum number of sites available in the head range from 3.5 to 6.0 m.

STANDARD WATER MILLS

In order to design standard water mills, the available data of water mill sites were analysed and categorised into 3 categories depending on the head as (i) upto 3.0 m (ii) 3.0 to 7.0 m and (iii) 7.0 to 15.0 m. Based on the site data available a database has been prepared. To utilize the potential of these water mill sites and to cover the entire range of water mill sites, 3 different systems are suggested to fulfill various needs of local peoples. The specifications of standard runners recommended are given in Table 2.

Table 2 : Specifications of Standard Runners

S. No.	System	Head Range (m)	Power Output (kW)	Speed (rpm)	Diameter (mm)	Height of Blade (mm)	Width of Blade (mm)
					750	160	187
1	For Cereals Grinding only	Upto 3.0	Upto 1.0	70-100	750	160	187
2	For Cereals Grinding & Electricity generating	3.0 to 7.0	2.0	125-225	500	100	125
3	For Electricity and other agro-processing (MPPU)	7.0 to 15.0	Upto 5.0	350-550	300	Length (mm)	
						300	

The developed systems are discussed below ;

VERTICAL SHAFT WATER MILL FOR GRINDING AND ELECTRICITY GENERATION

In the range of low head (Upto 3.0 m), inward flow impulse type runner is suggested. The runner would be capable to accommodate sufficient discharge in order to develop power upto 2.0 kW under a maximum head of 3.0 m. In order to accommodate more discharge to develop sufficient power under low head, the larger runner dia and larger size of vanes have been suggested. This system can be fitted with existing systems of traditional water mill. This will be suitable for grinding purpose only as its speed is low under low head and larger runner dia.

For grinding and electricity generation similar system having smaller runner diameter has been suggested. The system is also inward flow impulse type runner for operating head between 3 m to 7 m. Sufficient speed could be generated under a comparatively high head and small runner diameter by this runner. By introducing a speed increaser the system would be capable to derive a small alternator for lighting purpose in addition of grinding cereals. This system may also be installed as upgradation of existing traditional water mill.

The details of runner and layout of vertical shaft water mill system is shown in Fig.2 and Fig.3 respectively.

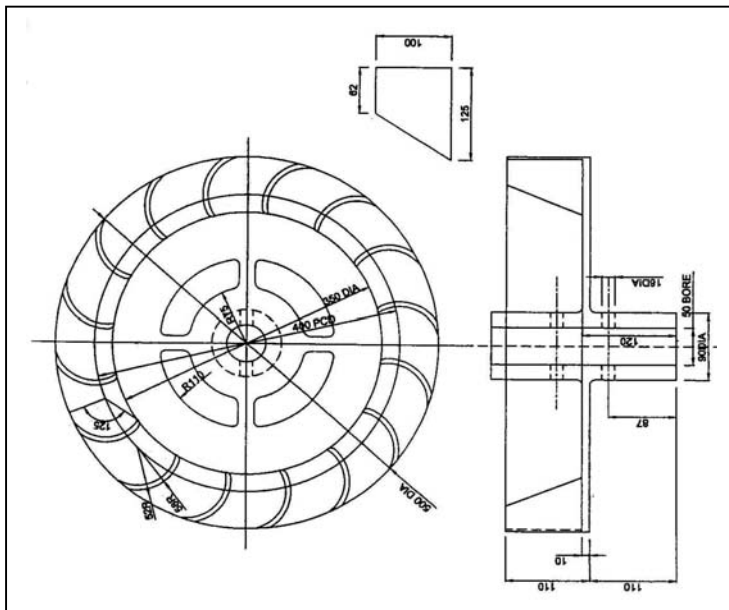

Fig. 2 : Details of Runner (Vertical Shaft Water Mill)

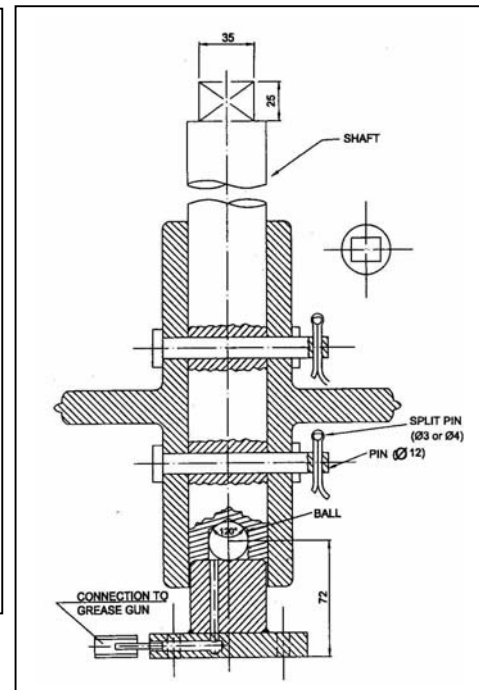

Fig. 3 : Layout of Vertical Shaft Water Mill Runner

HORIZONTAL SHAFT MULTIPURPOSE POWER UNIT (MPPU)

In order to develop mechanical power upto 5.0 kW, cross flow turbine runner is suggested. For this system, head range from 7.0 to 15.0 m has been considered for sizing the runner. Based on the past experiences it was recommended that ‘open cross flow’ turbine and over hung layout is economically viable option for this capacity range. The runner is cast in single piece, in order to reduce the fabrication cost.

At sites where sufficient hydro potential is available. Cross flow turbine is suitable for wider range of head and discharge for different end use applications. Recommended runner suitable for head range from 7-15 m for 5 kW power as most of the sites are in this range. The details of the runner and the layout of the system are shown in Fig. 4 and Fig. 5 respectively.

Further, the nozzle of the turbine is divided in $1/3^{\text{rd}}$ and $2/3^{\text{rd}}$ part to facilitate the operation of the runner at part load having good efficiency over a wider range under variable discharge conditions.

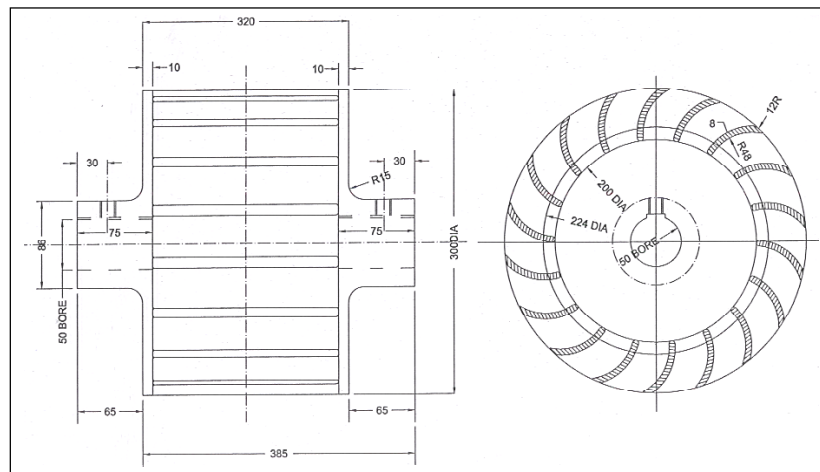

Fig. 4 : Details of Multipurpose Power Unit Runner

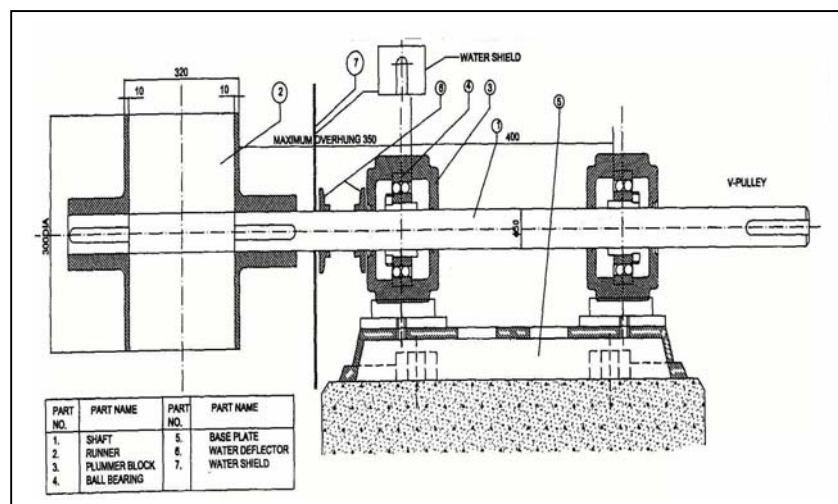

Fig. 5 : Horizontal Shaft Multipurpose Power Unit

COMPARISON OF EFFICIENCY OF STANDARD WATER MILL RUNNERS

An attempt was made to compare the performance of these runners. For the vertical shaft runner the variation has been observed in efficiency with respect to the speed of runner under different head for traditional water mill runner and improved water mill. It has been observed that the efficiency increases with decrease in speed. It is found that the efficiency of the improved water mill runner has been improved by 2-4 times.

It is also observed that under a given head, traditional water mill operated at lower speed than the improved water mill runner. The reason could be explained on the line that the traditional water mill runner is having larger diameter than the improved water mill runner. A comparison in efficiency is made based on the test data, which show that efficiency of improved water mill has been improved substantially. It is observed from the results that the average efficiency obtained of the runners ranges from 8 to 17% for traditional runner and 22 to 43% for improved runner.

To determine the efficiency of the open cross-flow runner having 300 mm runner diameter was tested on test rig of manufacturing unit [2]. Operating characteristics curves for different position of control valve show that the efficiency curve of the runner is quite flat which verify the characteristics of the conventional cross flow turbine.

At full opening of the control valves, a maximum efficiency of 74.5% corresponding to head of 14.5 m and discharge of 0.200 m³/s has been obtained and the initial input load has to be more than 5.75 kW corresponding to a discharge of 0.047 m³/s. It is also observed that the turbine efficiency over a discharge range from 0.150 to .0250 which is nearly flat.

At 2/3 opening of the valve the operating range of the turbine is observed for 0.110 to 0.200 m³/s and the initial input load has to be more than 6.26 kW corresponding to a discharge of 0.055 m³/s.

For the 1/3 opening of the valve the operating range of the turbine is obtained 0.090 to 0.140 m³/s and the initial input load has to be more than 5.85 kW corresponding to a discharge of 0.050 m³/s.

INSTALLATION

Installation of Vertical Shaft Water Mill

To enable the installation of the improved system well maintained and good quality tools are essential. The components of traditional water mill should be dismantled in order to fit the improved components. To ensure the shaft alignment in proper vertical position with respect to the cross bar over foot bearing at lower end and upper grinding stone at upper end, a centre mark should be made on the cross bar. Taking this mark as the centre of bottom bearing spindle, the plate of bearing is fixed by putting the nails with the cross bar. After placing runner over the bottom bearing from down stream side, place the shaft through the hole of lower grinding stone from upstream side. After alignment of shaft with the runner put the pin

through the holes of runner hub and shaft in order to fit the runner with the shaft. Now put the wooden bush inside the hole of lower grinding stone over the shaft.

After fitting the runner with the shaft, fix the rynd at the upper end of the shaft and place the upper grinding stone over the lower grinding stone. Fix all the remaining components. Alignment of the chute is one of the essential requirements of the water mill installation. In case of the new runner water jet must strike 3 blades at inside of the runner. Water flow from inside to outside direction as the runner is 'outward' flow type.

For the electricity generation, lower grinding stone is fixed with the gap of about 15-20 cm up from the mill house floor. In this gap a pulley is fitted with the shaft under lower grinding stone, which is fixed over a slab of concrete. This pulley is tight fitted with the shaft. Generator is fixed near the driven pulley. Layout of the installed system is as shown in Fig.6.

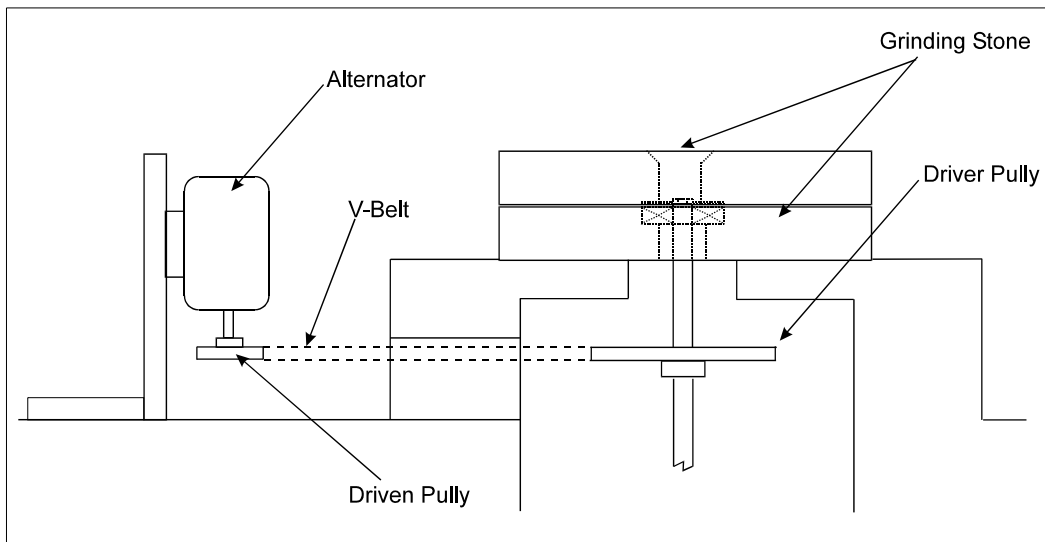

Fig. 6 : Lay out of the Vertical Shaft Water Mill having Electricity Generation System

Installation Of Multipurpose Power Unit (MPPU)

The installation process for Multipurpose Power Unit can be divided into 5 phases as follows;

- (a). Transportation of Equipments
- (b). Civil Constructions.
 - (i) Construction of electro-mechanical devices foundation and powerhouse
 - (i) Penstock installation
 - (ii) Construction of forebay
 - (iii) Construction of power vchannel
 - (iv) Intake works

- (c). Installations of Electrical and Mechanical Equipments.
 - i. Machine foundations
 - ii. Machine installation
 - iii. Alignment
- (d). Installation of transmission lines
- (e). Installation of distribution and service lines.

The construction of the scheme should be started from the most critical location; i.e., where a slight misalignment or improper orientation may result in significant expenditure for remedial measures. Usually the machine foundation in the powerhouse is the most critical location. This is because once the machine foundation anchor bolts are set in concrete; the turbine and the generator locations cannot be readjusted. Therefore, first the machine foundation should be constructed. Then work should commence on the installation of the penstock pipe from the machine foundation to the forebay. The anchor blocks should also be completed after the entire penstock pipe length has been installed. This is because once anchor blocks are constructed; the penstock pipe cannot be readjusted.

Once the machine foundation, penstock and the forebay have been constructed, the logical sequence is to continue the construction work upstream until the location of the intake is reached. If the construction work is commenced in this sequence, there will be fewer chances of misalignment or errors in the elevation of the structures. Construction work at the intake and especially the diversion weir should normally start when all other structures are completed.

OPERATION AND MAINTENANCE

Operation of Vertical Shaft Water Mill

Correct operation of the system is beneficial in many ways. Managers and operators must be fully familiar with the equipment, its functions and operational procedures. Technical specifications must also be known and properly recorded in the Operations & Maintenance Manual provided by the installer.

In case of vertical shaft water mill, the following checks should be made during starting, stopping and running of unit. At any stage if a problem is noticed; say, unusual sound, the unit should be stopped and the problem rectified before starting or running the unit.

- (a) Follow the specified procedure for cleaning up the civil works as applicable.
- (b) Visually inspect all components (e.g. Bottom bearing, Runner, Shaft, Pin, bush, stones, hopper, lift mechanism and vibrator etc.)
- (c) Ensure that jet of water aimed properly to the runner blades.
- (d) Keep sufficient gap between stones to rotate upper stone smoothly in the beginning.
- (e) Increase the discharge slowly so that stone along with the wheel pick up the speed.
- (f) By operating lift mechanism keep the gap as desired based on the quality of flour is required.

Operation of Multipurpose Power Unit

For operating of Multipurpose Power Unit the following checks should be made during starting, stopping and running of unit.

The start up procedure

(i) for water and turbine

- (a) Follow the specified procedure for cleaning up the civil works as applicable.
- (b) Visually inspect all equipment (e.g. turbine, generator, control panel etc.)
- (c) Ensure that penstock and turbine valves are closed.
- (d) Turn on water at intake.

(ii) for electricity

- (a) Check that all switches on the load side are in the "OFF" position.
- (b) Inform users that unit will be starting.
- (c) If belts are removed, put them on the pulleys, check belt tension also.
- (d) Gradually let water into the turbine by opening the turbine valve.
- (f) If there are any push button switches for exciting the generator, press the voltage rises up to 200 V.
- (g) Increase water flow by opening turbine valves further until the speed, and power comes up to desirable/rated level.
- (h) For plants having ELC, gradually divert power to the load by switching the load switches.
- (i) If there is no load controller increase the water flow until the voltage rises 220 V while the load is connected.
- (j) The allowable voltage fluctuation, for such units is within $\pm 10-15\%$.

(iii) for agro-processing

- (a) Check all nuts, bolts, etc. of agro-processing machinery; move everything away from the drive system.
- (b) Engage the belt from the turbine to the line shaft and then to the machine.
- (c) If there is no line shaft, place the belt directly from the turbine to the machine; for example, rice huller.
- (d) Admit grains to the huller, oil seed to the expeller, etc.
- (e) Let water into the turbine, gradually opening the turbine valve until the required speed is reached.
- (f) Listen for any abnormal noise or vibration when the unit is running. Stop the turbine if this happens and look for the fault.
- (g) Check drive systems (belt, coupling, etc.)
- (h) Connect only those units simultaneously for which power is sufficient.

- (i) If the turbine is powering a generator and agro-processing equipment simultaneously priority goes to electricity and connect the agro- processing unit only if sufficient additional power (i.e flow) is available.

the shutting down procedure

Following procedure should be followed prior to and during shutting down of the unit.

- (a) Inform users that the unit will be shut down, if time permits (unless they already know, in the case of regular shut downs).
- (b) Switch 'OFF' all connected load.
- (c) Close turbine control valve gradually to prevent rapid penstock pressure rise.
- (d) Close penstock valve.
- (e) Stop water from forebay tank and intake if necessary.
- (f) Ensure that powerhouse and equipment are clean and tidy.

Maintenance Of Vertical Shaft Water Mills

For the maintenance of vertical shaft water mill, the following points should be followed ;

Maintenance of chute inlet

To make the flow smooth from power channel to the chute the joint should be maintained properly.

Maintenance of water chute

With use, the surface of water chute gets worn out and the surface in contact with water becomes rough, having loss of head due to friction. Try to make this surface smooth by maintaining it properly.

Bottom bearing ball

The alignment of the shaft, some time gets disturbed, due to the thrust of the water jet through chute. This misalignment results in the wobbling in the runner. This may damage the foot bearing and hub of the runner. It is suggested to the owner/operator that he should check the alignment of the shaft regularly, if there is any mis-alignment then find out the cause and rectified it immediately.

Alignment of the shaft

The bottom bearing ball fitted with the shaft revolves over the foot bearing spindle. This ball worn out over a period of time. The replacement of the ball with new one is required. However life of the ball may be increased by providing proper lubrication. Owner/ operator must ensure the lubrication before starting the system. At the end of the shaft, a hole has been embedded. By striking the nail with hammering device the ball inside the hole in the shaft is

drawn outside. For inserting the new ball in the given hole of the shaft the wooden batten is stroked on the outer surface of the shaft. Procedures of the replacing the ball is shown below.

Stones dressing

Dressing of stones is very important to increase the output of the water mills. Stones grooving are necessary to be made scientifically. It is very necessary that grooves should be maintained time to time and proper.

Maintenance Of Multipurpose Power Unit

For the maintenance of Multipurpose Power Unit following points should be noted.

Before start up

- (a) Clean the trash racks at the intake, desilting basin and forebay.
- (b) Check whether sufficient water is flowing -through the headrace.
- (c) If not; the plant load should be reduced accordingly or it should not be started at all.
- (d) Flush the forebay and desilting basin during the monsoons (every other day if the debris amounts are less).

During operation

- (a) Check the temperatures and vibration level of housings/casings of bearings of turbine and generator.
- (b) Check the leakage from valves, turbine housing, or base frame.
- (c) If the leakage is excessive from any location, repairs should be organized straight away in due course as the situation demands.

Good and timely preventive maintenance would almost always help to reduce the number of breakdowns and increase the life and productivity of the equipment. A check list and schedule for routine maintenance should be maintained for proper maintenance.

CONCLUSIONS

Based on the available water mill sites data in Uttaranchal, 3 standard water mills have been suggested. Prototypes of improved designs were fabricated and tested in the laboratory. For vertical shaft improved water mill, a comparison in efficiency has been made based on the test data. These test result shows a substantial enhancement in the efficiency of improved water mill. It has been observed from the test results that the average efficiency obtained of the runners ranges from 8 to 17% for traditional runner has been improved upto 22 to 43% for improved runner. In case of Cross Flow turbine runner for Multipurpose Power Unit, the efficiency has been found as 75%. The installation, operation and maintenance of such systems in brief have also been discussed.

REFERENCES

1. Final Report on “Water Mills” prepared by AHEC, IIT Roorkee for UNDP-GEF Hilly Hydro Project, MNES, GOI, New Delhi, July 2001.
2. Report on the Project “Development of Standard Water Mills in Uttaranchal” prepared by AHEC, IIT Roorkee for Technology Information, Forecasting & Assessment Council (TIFAC), DST, GOI, New Delhi, Oct. 2005.