

After alignment of shaft with the runner put the pin through the holes of runner hub and shaft in order to fit the runner with the shaft. Now put the wooden bush inside the hole of lower grinding stone over the shaft.

### Step V : Fitting the Remaining Components

After fitting the runner with the shaft, fix the rynd at the upper end of the shaft and place the upper grinding stone over the lower grinding stone. Fix all the remaining components.

### Step VI : Alignment of Water Jet

Alignment of the chute is one of the essential requirement of the water mill installation. In case of the new runner water jet must strike 3 blades at

inside of the runner. Water flow from inside to outside direction as the runner is 'outward' flow type.

## ❖ MAINTENANCE

### Maintenance of Chute Inlet

To make the flow smooth from power channel to the chute the joint should be maintained properly.

### Maintenance of Water Chute

With use, the surface of water chute gets worn out and the surface in contact with water becomes rough, having loss of head due to friction. Try to make this surface smooth by maintaining it properly.

### Bottom Bearing Ball

The alignment of the shaft, some time gets disturbed, due to the thrust of the water jet through chute. This misalignment results in the wobbling in the runner. This may damage the foot bearing and hub of the runner. It is suggested to the owner/operator that he should check the alignment of the shaft regularly, if there is any mis-alignment then find out the cause and rectified it immediately.

### Alignment of the Shaft

The bottom bearing ball fitted with the shaft revolves over the foot bearing spindle. This ball worn out over a period of time. The replacement of the ball with new one is required. However life of the ball may be increased by providing proper lubrication. Owner/ operator must ensure the lubrication before starting the system.

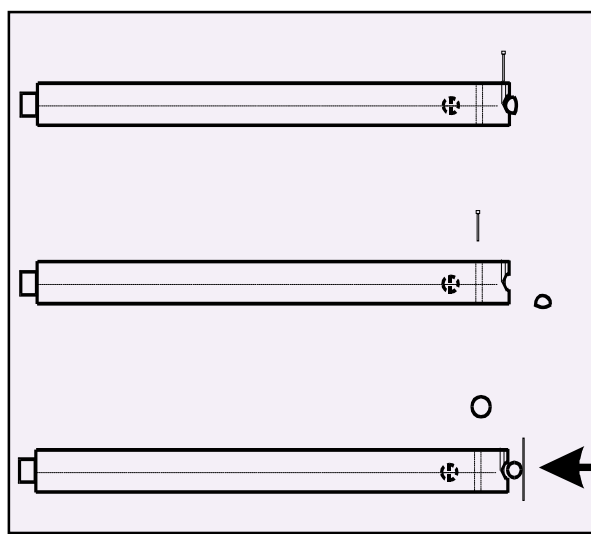

### Stones Dressing

Dressing of stones is very important to increase the output of the water mills. Stones grooving are necessary to be made scientifically. It is very necessary that grooves should be maintained time to time and proper.

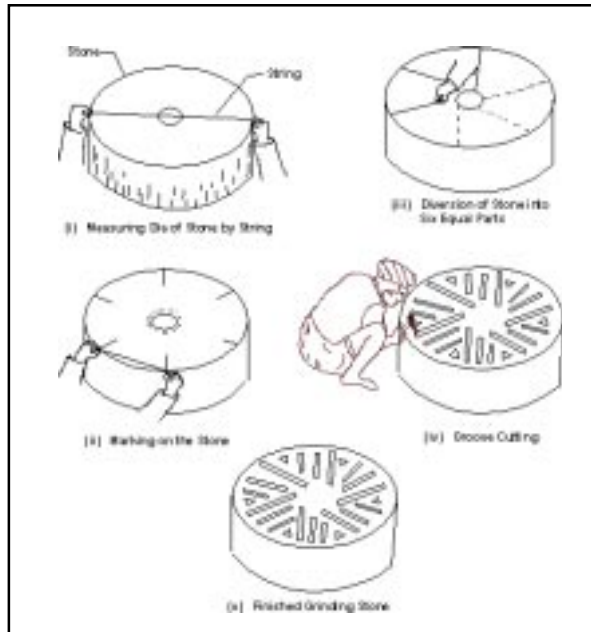

### Acknowledgement :

Ministry of Non-Conventional Energy Sources (MNES) under its project UNDP-GEF Hilly Hydro Projects has provided financial support and inputs from international experts for the development of water mills is acknowledged with appreciation and thanks.

## ABOUT AHEC

Alternate Hydro Energy Centre (AHEC) was set up at Indian Institute of Technology Roorkee (formerly University of Roorkee) by the Ministry of Non-Conventional Energy Sources (MNES), Govt. of India, in the year 1982 to promote power generation through the development of small hydro in hilly as well as in plain areas. AHEC offers a variety of services in the field of small hydro power development and other interdisciplinary areas.

### Small Hydro Power

- \* Refurbishment, renovation and modernisation of SHP stations.
- \* Detailed project reports, engineering designs and construction drawings.
- \* Technical specifications.
- \* Pre-feasibility reports.
- \* Planning, designs and execution.
- \* Techno-economic appraisal.
- \* Monitoring of projects.
- \* Remote sensing and GIS based applications.

### Other Fields

- \* Power system planning and operation.
- \* Energy Auditing.
- \* Drainage/irrigation related projects.
- \* Environment impact assessment and Ecorestoration.
- \* R&D in the field of other renewable energy sources (Solar, Biomass, Wind etc.)

### Human Resources Development

- \* Training to the field engineers and technologists.
- \* Offers a three semesters M. Tech Course in AHES.
- \* Information dissemination, exhibitions, workshops/seminars.



### Head

Alternate Hydro Energy Centre  
 Indian Institute of Technology Roorkee  
 (formerly University of Roorkee)  
 Roorkee-247 667 (Uttaranchal), India  
 Phone(office) : 0091-1332 74254, 85213, 85841  
 (Residence) : 0091-1332-73270  
 FAX : +91 1332-73517 or 73560  
 Gram : ENERGYCENTRE, ROORKEE  
 E-Mail : ahec@iitr.ernet.in, ahec@vsnl.com  
 Web Site : www.ahec.org.in  
 www.hydrohelp.com

# IMPROVED WATER MILL

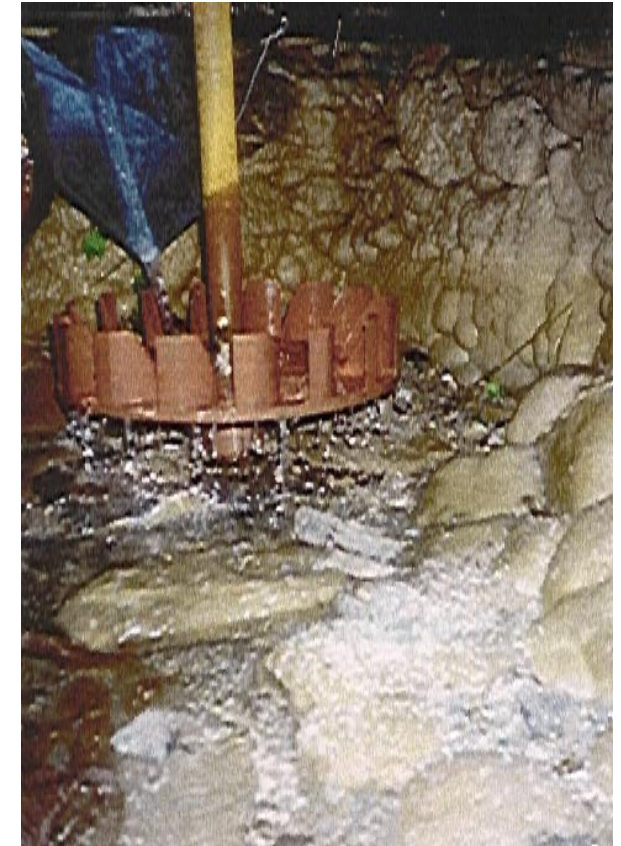

## INSTALLATION AND MAINTENANCE MANUAL



Alternate Hydro Energy Centre,  
 Indian Institute of Technology,  
 Roorkee - 247 667

## ❖ BACKGROUND

In the hills water mills, commonly known as ‘gharats’ have significant role in utilisation of mechanical power from water streams, mainly for grinding purpose. The design of traditional gharat is quite old and very little modification has been done over the years in the gharat designs. Throughout the Himalayan ranges from Kashmir to Arunachal Pradesh, thousands of water mills are being used for grinding cereals. By the input of technical enrichment the efficiency of traditional water mill can be increased upto 3 times. Alternate Hydro Energy Centre (AHEC), Indian Institute of Technology Roorkee (IITR), Roorkee has been involved in development of water mills. Based upon the field experiences an improved water mill for upgradation has been developed.

## ❖ TRADITIONAL WATER MILL

Traditional water mill consists of a wooden turbine with straight wooden blades, fitted inclined to a thick vertical wooden shaft tapering at both ends. The water chute consists of an open channel either made from wooden planks or carved from a large tree trunk. The chute is narrowed down toward the lower end forming a nozzle.

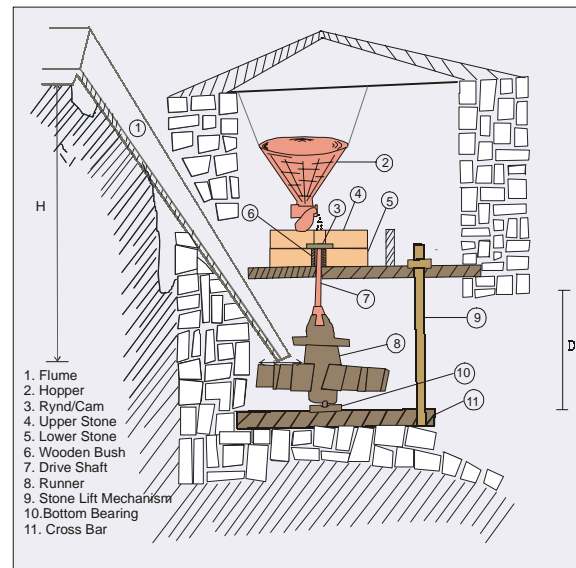

Traditional Water Mill

The wooden shaft of the turbine is supported on a stone pivot through a steel pin and held in the sliding bearing at the top. The sliding bearing is a wooden bush fixed in the lower stationary grinding stone. The top grinding wheel rests on the lower stone and is rotated by the turbine shaft through a straight slot coupling. The gap between the stone is adjusted by lifting the upper stone with the help of lift mechanism.

## ❖ IMPROVED WATER MILL

A vertical shaft Water Mill upto 3 kW mechanical output has been developed by AHEC under UNDP-GEF Hilly Hydro Projects of Ministry of Non-Conventional Energy Sources (MNES), Govt. of India. The developed system is capable to provide an efficient and long life machine useful for grinding cereals at a faster rate with minimal maintenance. The improved runner ensures the enhancement of efficiency by 3-5 times over the traditional water mill. The improved runner is very easy to install and can be fitted with other parts of the existing water mills which are generally found in good conditions and do not have significant effect on the output of the water mill. The parts of the machines are very simple and are easy to understand by local people. The newly designed water mill consists of the following components :

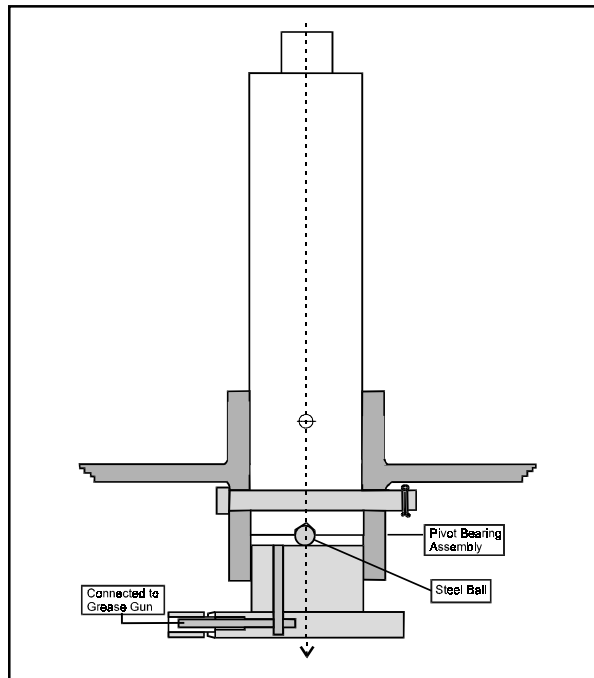

Improved Water Mill

## Runner

The diameter of the runner is about 500 mm having 16 blades. The complete runner is cast in single-piece and having about 30 kg.

## Drive Shaft

A steel shaft of 50 mm diameter has been used as a drive shaft. The upper end of the shaft is cut in rectangular form to fit the rynd/cam for upper stone attachment.

## Bottom Bearing

A very simple bottom bearing having a ball which is press fitted at the lower end of the shaft, which rests on a piece of hard steel.

## Wooden Bush

A simple oil soaked wooden bush made of hard wood is used in the upper stone hole to hold the shaft straight and aligned vertical.

## Rynd or Cam

Cam is used for revolving the upper stone over the bottom stone fitted with driving shaft.

## Upper Stone Lift Mechanism

The lift mechanism is a steel bar having a rotating wheel at its upper end and pin at lower end. The lower end is fitted to the cross bar with the help of the pin.

## Grinding Stones

Existing grinding stones can be used for new installation as these are found, generally in good conditions.

## Flume/Chute

The existing flume can be reused by providing the lining of G.I.

## Feeding Mechanism

At existing sites feeding mechanism consists of a hopper with a vibrator can be reused.

## ❖ INSTALLATION PROCEDURE

### Step I : Ensure the Tools

To enable the installation of the improved system well maintained and good quality tools are essential. First of all, check all the tools such as; Hammer, Sheet cutter, File, Grease Gun, Hacksaw, Plumb, Screw driver, Draw bar, Sprit level, Spanner, Wood saw, Chisels.

## Step II : Dismantling of Traditional Water Mill Components

The components of traditional water mill should be dismantled in order to fit the improved components.

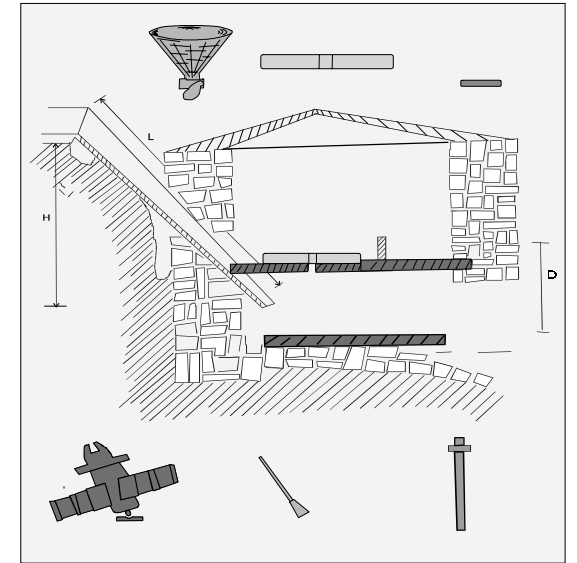

### Step III : Fitting of Bottom Bearing

To ensure the shaft alignment in proper vertical position with respect to the cross bar over foot bearing at lower end and upper grinding stone at upper end, a centre mark should be made on the cross bar. Taking this mark as the centre of bottom bearing spindle, the plate of bearing is fixed by putting the nails with the cross bar.

### Step IV : Shaft Fixing with Runner

After placing runner over the bottom bearing from down stream side, place the shaft through the hole of lower grinding stone from upstream side.

